

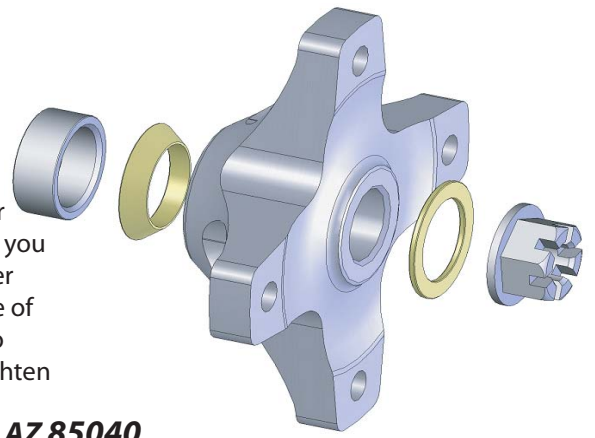

Congratulations on purchasing your new 2nd Generation Lone Star Micro-Lite Rear Wheel hubs. Installation is as shown here. Use the smaller inner diameter washer if you are running your axle to the full width. If you run your hubs narrower, use the bigger inner diameter washer. Make sure the washer touches the hub on the outer surface of the hub. Failure to run washers will result in a voided warranty. Tighten axle nuts to manufacturers specs, and install cotter pin. After the first few hours of riding, re-tighten the nuts to ensure a long life.

LONE STAR RACING - 1424 E. BROADWAY RD. PHOENIX, AZ 85040
1-800-4LS-RACE WWW.LSRACING.COM



Congratulations on purchasing your new 2nd Generation Lone Star Micro-Lite Rear Wheel hubs. Installation is as shown here. Use the smaller inner diameter washer if you are running your axle to the full width. If you run your hubs narrower, use the bigger inner diameter washer. Make sure the washer touches the hub on the outer surface of the hub. Failure to run washers will result in a voided warranty. Tighten axle nuts to manufacturers specs, and install cotter pin. After the first few hours of riding, re-tighten the nuts to ensure a long life.

LONE STAR RACING - 1424 E. BROADWAY RD. PHOENIX, AZ 85040
1-800-4LS-RACE WWW.LSRACING.COM

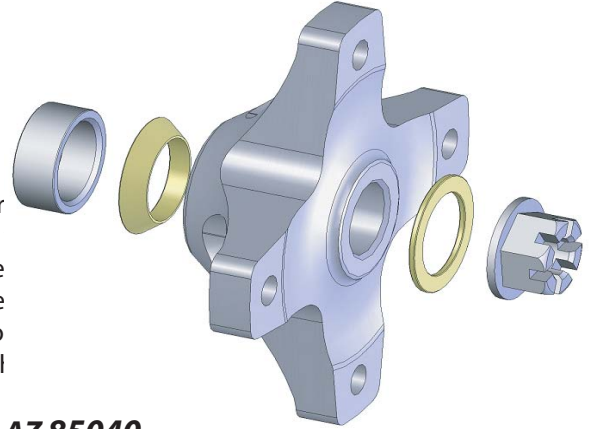

Congratulations on purchasing your new 2nd Generation Lone Star Micro-Lite Rear Wheel hubs. Installation is as shown here. Use the smaller inner diameter washer if you are running your axle to the full width. If you run your hubs narrower, use the bigger inner diameter washer. Make sure the washer touches the hub on the outer surface of the hub. Failure to run washers will result in a voided warranty. Tighten axle nuts to manufacturers specs, and install cotter pin. After the first few hours of riding, re-tighten the nuts to ensure a long life.

LONE STAR RACING - 1424 E. BROADWAY RD. PHOENIX, AZ 85040
1-800-4LS-RACE WWW.LSRACING.COM

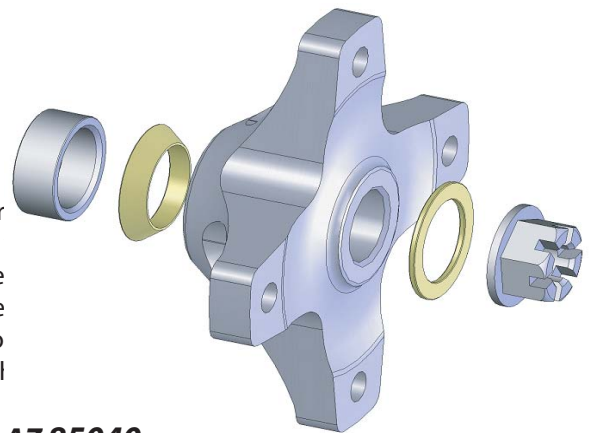

Congratulations on purchasing your new 2nd Generation Lone Star Micro-Lite Rear Wheel hubs. Installation is as shown here. Use the smaller inner diameter washer if you are running your axle to the full width. If you run your hubs narrower, use the bigger inner diameter washer. Make sure the washer touches the hub on the outer surface of the hub. Failure to run washers will result in a voided warranty. Tighten axle nuts to manufacturers specs, and install cotter pin. After the first few hours of riding, re-tighten the nuts to ensure a long life.

LONE STAR RACING - 1424 E. BROADWAY RD. PHOENIX, AZ 85040
1-800-4LS-RACE WWW.LSRACING.COM

