



# RZR CHASSIS FRONT UPPER A-ARM MOUNT GUSSET PLATE

**TOOLS NEEDED:** #25 Torx Bit  
3/8 Ratchet  
8mm Allen Socket  
17mm wrench  
3/8 socket

Congratulations on purchasing your new Gusset Plate. This plate will add a significant amount of strength to the front of the chassis.

We also suggest the bolt on Rear Main Gusset Plate, and the weld in Gusset Kit we offer separately. Contact your LSR sales rep for details.

## INSTALLATION:

The installation of this gusset plate is pretty straight forward. 1st you will need to remove the front plastic assembly from the RZR using the #25 Torx bit to gain access to the lower radiator mount. Remove the 4 bolts from the lower radiator mount using the 3/8 socket. Slide in the plate as shown below. Make sure the brake line and breather lines are not pinched or obstructed. Install the 2 10mm bolts into the rear of the plate through the steering rack mount. Leave them loose. Install the front 10mm bolts with nuts, and leave them loose. Next, install the upper radiator bolts, and leave them loose. The next step is a little tricky. You need to pull down on the radiator mount to stretch it open a bit from the new width of the gusset plate. Install the front bolts. Once you have all bolts installed loosely, go ahead and tighten all bolts. Then install the front plastic.

## PARTS INCLUDED:

- 1 - Gusset Plate
- 4 - M10 x 18mm Bolts
- 2 - M10 x 1.5 Nylon Lock Nuts

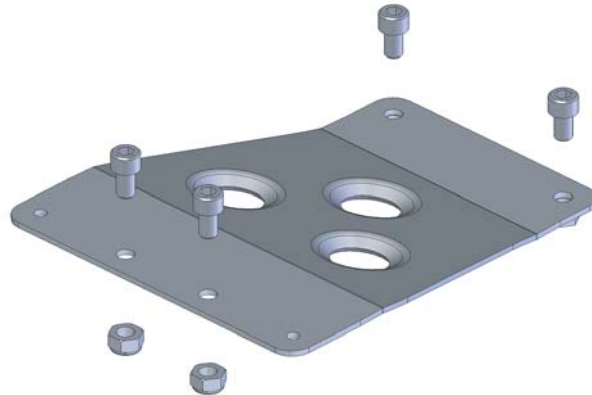

Radiator mount stretched open to fit thickness of new plate underneath.

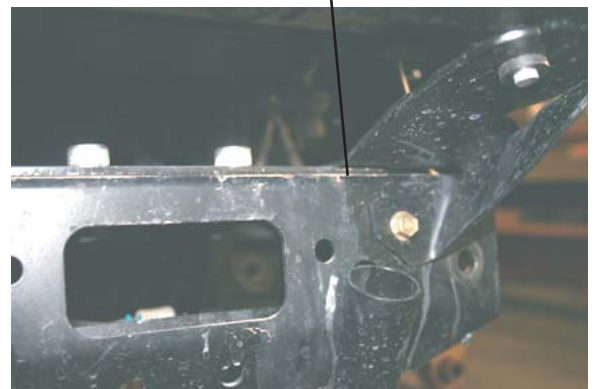

## CLEANING/ MAINTAINING:

The gusset plate can be cleaned with soap and water. You will want to check the mounting bolts for tightness periodically.